

### B03 schematic:

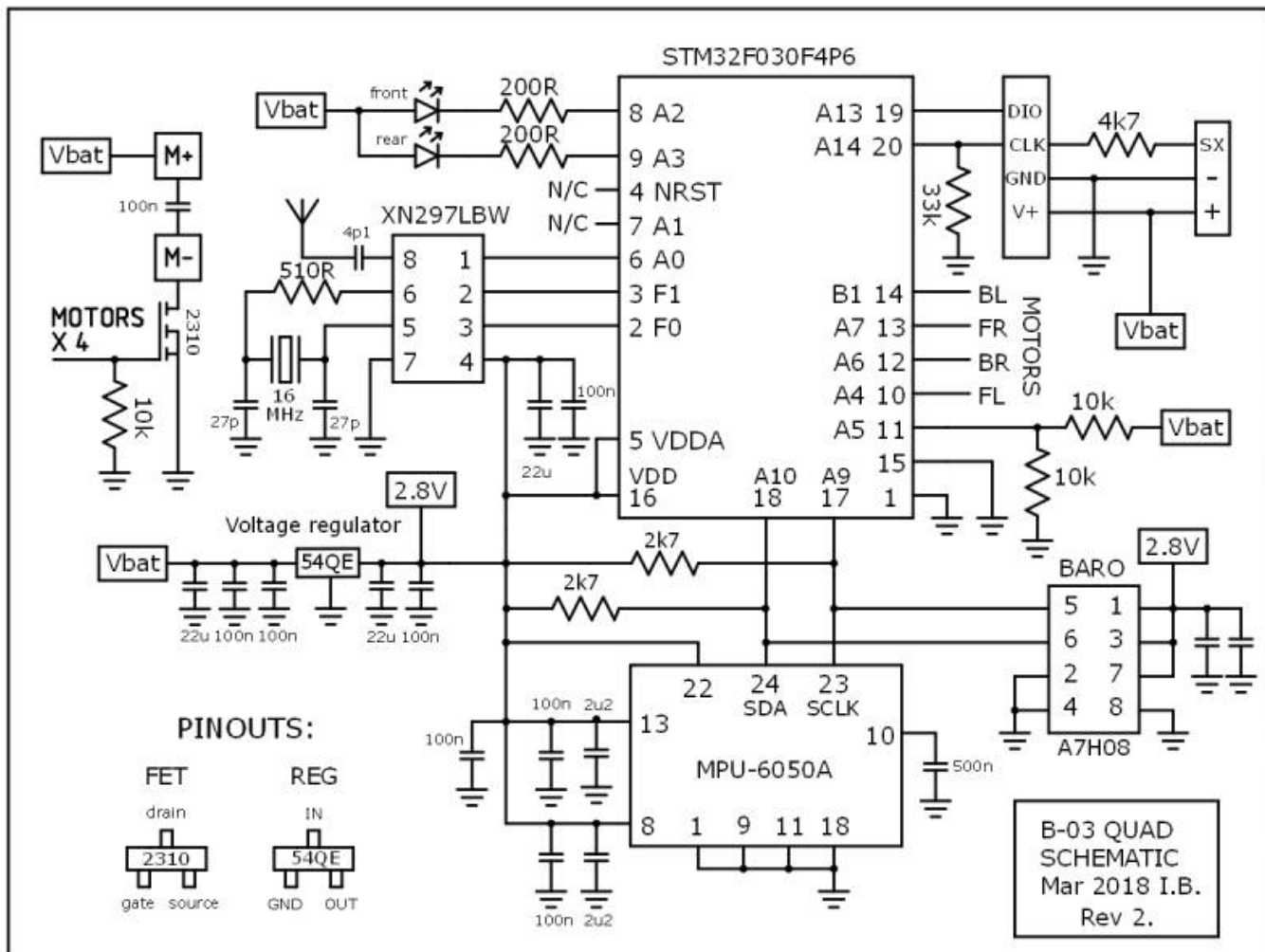

### E011 schematic:

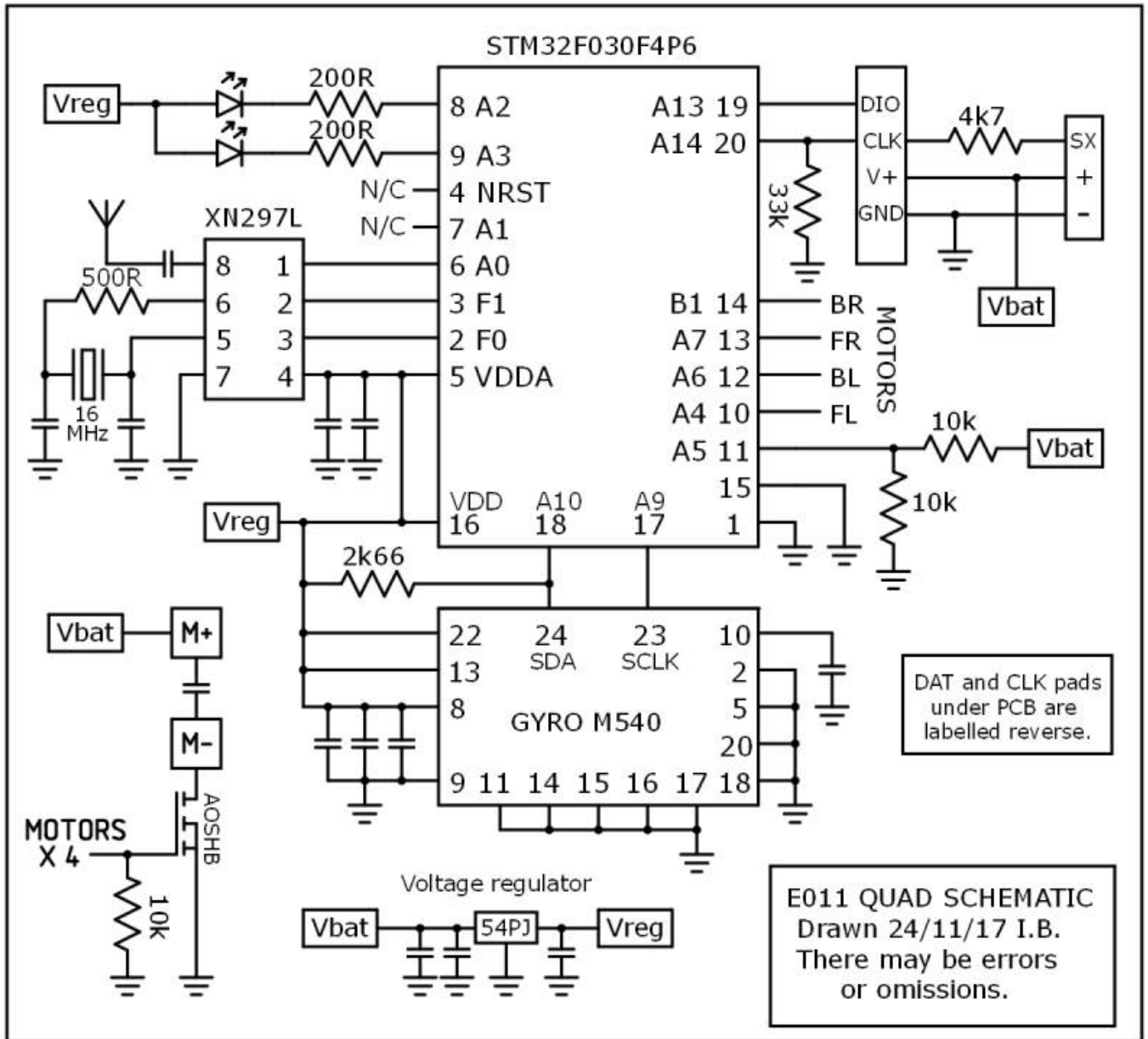

H8 mini blue schematic:





